



DEPARTMENT OF COMMUNITY DEVELOPMENT SERVICES

Planning Division

m e m o r a n d u m

TO: The Urbana Plan Commission
FROM: Kevin Garcia, AICP, Planner II
DATE: August 31, 2018
SUBJECT: Plan Case 2349-S-18: Union Gardens Preliminary Plat

This is a supplement to the staff memorandum dated August 17, 2018, regarding the Union Gardens Preliminary Plat. The original memorandum included a series of plat sheets as an attachment. However, the applicant had submitted larger-scale plat sheets that should have been included in the original attachment. The additional sheets are attached to this memorandum, and represent the preliminary plat in its entirety for Plan Commission to review.

In addition, the plat review letter that was initially sent to outside agencies did not include all of the required plat sheets. The agencies have since been mailed the additional sheets. The new plat review period ends on September 4, 2018. Staff therefore amends its earlier recommendation regarding the preliminary plat to reflect this new date, as follows:

Staff recommends that the Plan Commission **APPROVE** the Preliminary Plat in Case No. 2349-S-18 **with the following CONDITION:**

1. The petitioner shall address any outstanding comments from City staff or from outside agencies received on or before September 4, 2018.

Attachments: Exhibit G: Preliminary Plat Sheets

CC: Kimberly Hansen (Trinitas Development LLC)

Exhibit G - Preliminary Plat Sheets

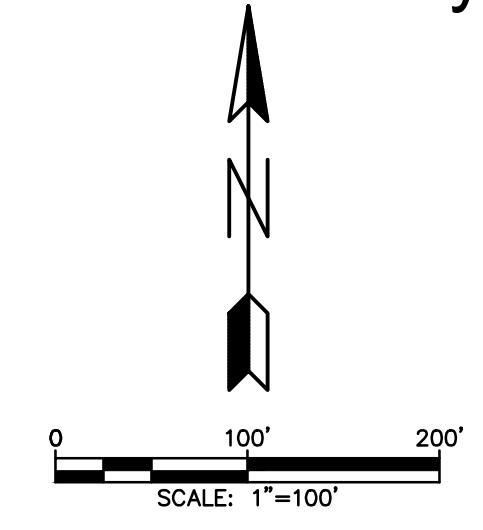

P.L.N.
 TRACT 1: 91-21-06-451-005
 TRACT 2: 30-21-06-326-015
 TRACT 3: 46-21-06-376-007
 TRACT 3: 46-21-06-376-008

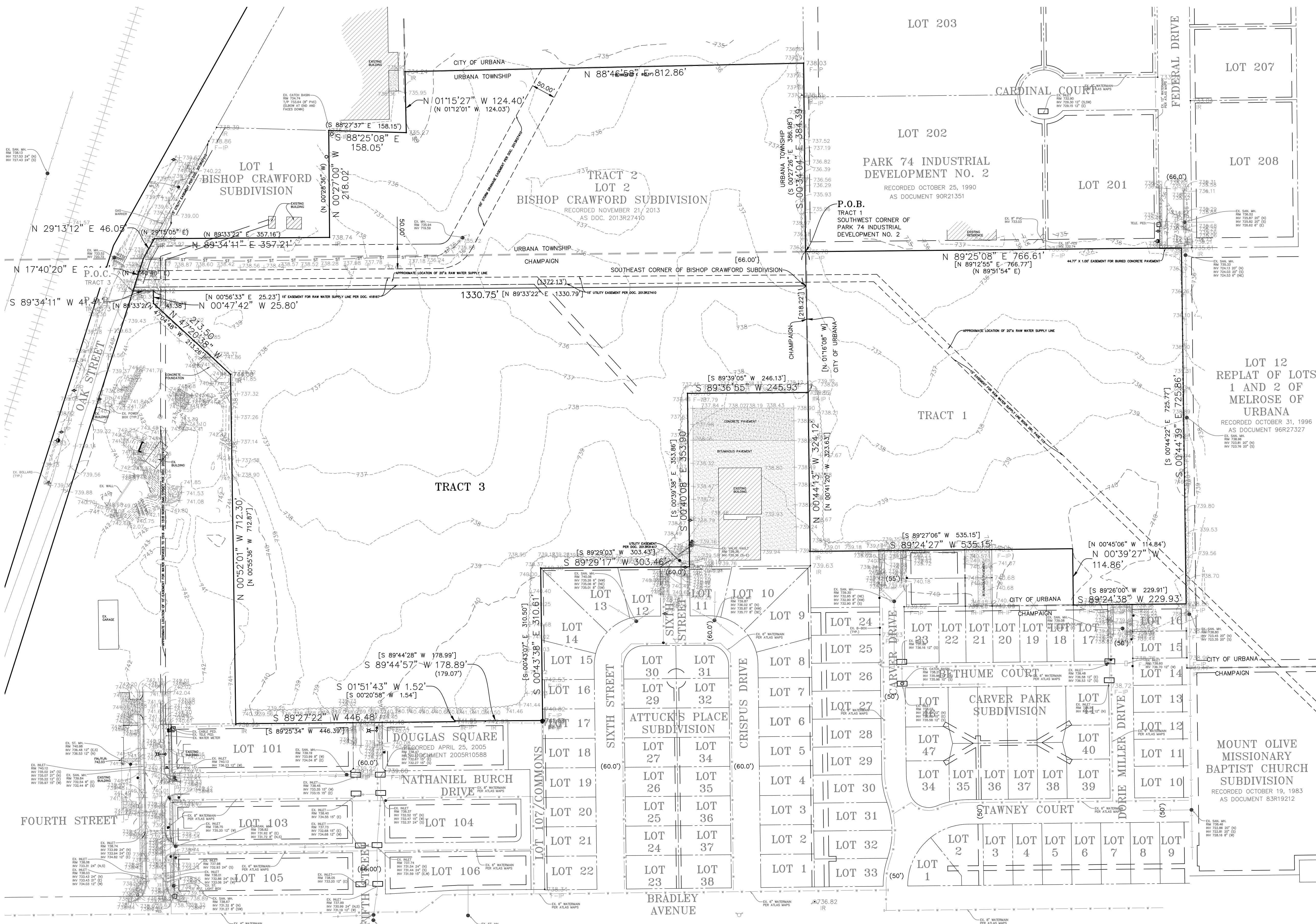

LEGEND		ABBREVIATIONS	
—	EX. PROPERTY LINE	A	ARC LENGTH
- - -	EX. LOT LINE	CH	CHORD
- · - · -	EX. EASEMENT LINE	CONC.	CONCRETE
- - - - -	EX. CORPORATE LIMITS	E	EAST
		FIP	FOUND IRON PIPE
		FR	FOUND IRON ROD
		N	NORTH
		R	RADIUS
		R.O.W.	RIGHT OF WAY
		S	SOUTH
		W	WEST
		B.S.L.	BUILDING SETBACK LINE
		DOC.	DOCUMENT
		(xxx.xx)	RECORD INFORMATION
		[xxx.xx]	DEED INFORMATION
		xxx.xx	MEASURED INFORMATION

SURVEY AREA TABLE	
TRACT 1:	494,043 SQUARE FEET (11.342 ACRES±)
TRACT 2:	455,374 SQUARE FEET (10.454 ACRES±)
TRACT 3:	795,274 SQUARE FEET (18.257 ACRES±)
TOTAL:	1,744,691 SQUARE FEET (40.053 ACRES±)

REVISIONS:					
DATE	BY	DESCRIPTION	DATE	BY	DESCRIPTION

DRAWN BY: S.F.
 CHECKED BY: N.V.
 APPROVED BY: N.V.



ENGINEERING RESOURCE ASSOCIATES
 35701 WEST AVENUE, SUITE 150
 WARRENVILLE, ILLINOIS 60555
 PHONE (630) 393-3060
 FAX (630) 393-2152

10 S. RIVERSIDE PLAZA, SUITE 875
 CHICAGO, ILLINOIS 60606
 PHONE (312) 474-7841
 FAX (312) 474-6099

2416 GALEN DRIVE
 CHAMPAIGN, ILLINOIS 61821
 PHONE (217) 351-6268
 FAX (217) 355-1902

PREPARED FOR:
TRINITAS DEVELOPMENT LLC

TITLE:
**UNION GARDENS
 EXISTING TOPOGRAPHICAL PLAN
 OVERALL**

SCALE: 1"=100'
 DATE: 7-27-2018
 JOB NO: 180306
 SHEET 2 of 24

Exhibit G - Preliminary Plat Sheets

P.I.N.
 TRACT 1: 91-21-06-451-005
 TRACT 2: 30-21-06-326-015
 46-21-06-376-007
 TRACT 3: 46-21-06-376-008

SURVEY AREA TABLE
 TRACT 1: 494,043 SQUARE FEET (11.342 ACRES±)
 TRACT 2: 455,374 SQUARE FEET (10.454 ACRES±)
 TRACT 3: 795,274 SQUARE FEET (18.257 ACRES±)
 TOTAL: 1,744,691 SQUARE FEET (40.053 ACRES±)

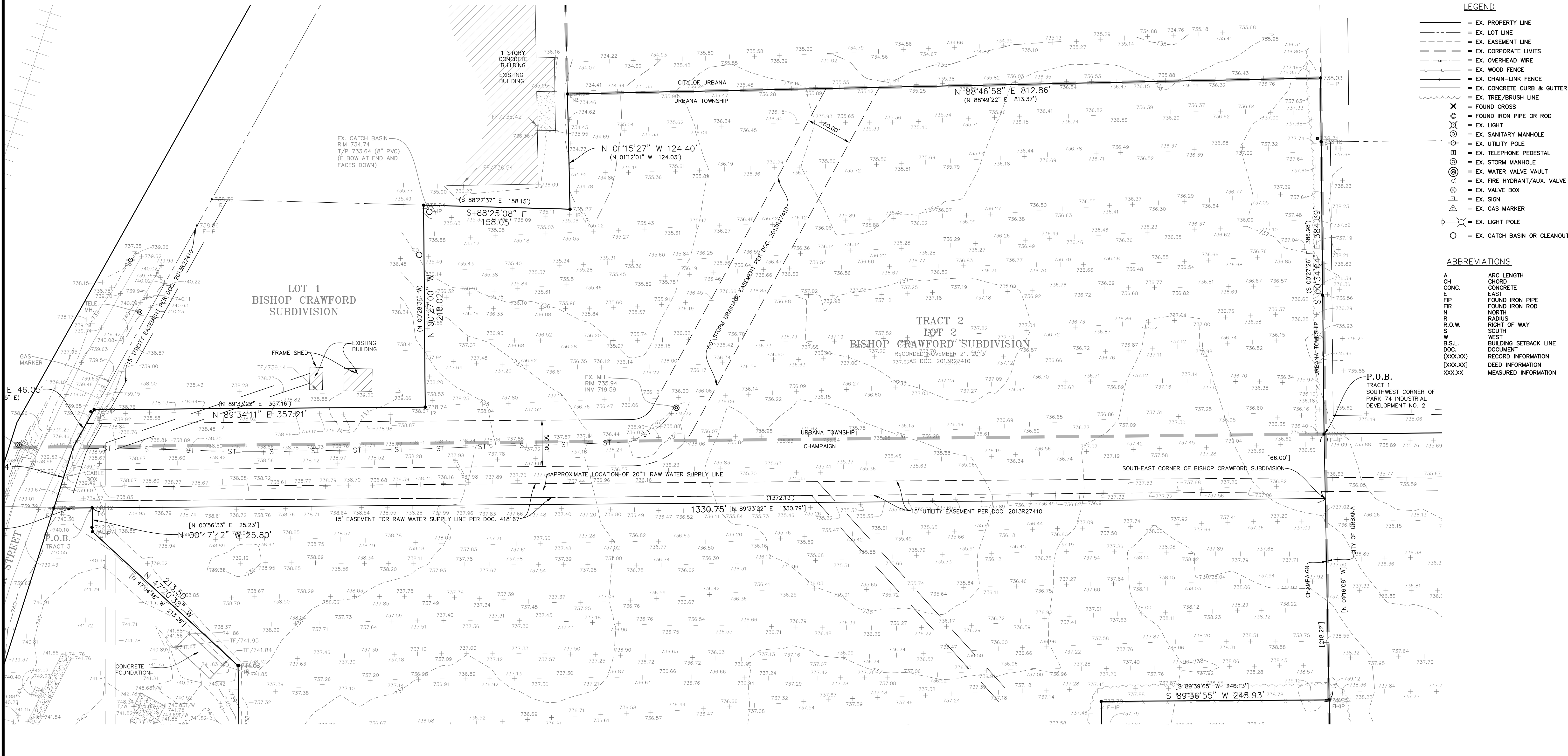
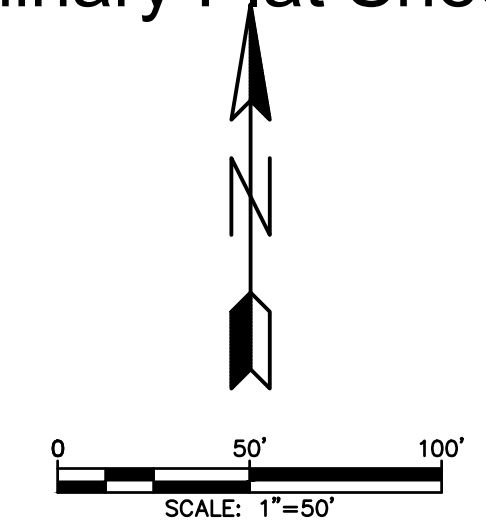

- LEGEND**
- = EX. PROPERTY LINE
 - - - = EX. LOT LINE
 - · - · - = EX. EASEMENT LINE
 - · - · - · = EX. CORPORATE LIMITS
 - · - · - · - · = EX. OVERHEAD WIRE
 - · - · - · - · - · = EX. WOOD FENCE
 - · - · - · - · - · - · = EX. CHAIN-LINK FENCE
 - · - · - · - · - · - · - · = EX. CONCRETE CURB & GUTTER
 - · - · - · - · - · - · - · - · = EX. TREE/BRUSH LINE
 - X = FOUND CROSS
 - ⊗ = FOUND IRON PIPE OR ROD
 - ⊙ = EX. LIGHT
 - ⊖ = EX. SANITARY MANHOLE
 - ⊕ = EX. UTILITY POLE
 - ⊞ = EX. TELEPHONE PEDESTAL
 - ⊟ = EX. STORM MANHOLE
 - ⊠ = EX. WATER VALVE VAULT
 - ⊡ = EX. FIRE HYDRANT/AUX. VALVE
 - ⊢ = EX. VALVE BOX
 - ⊣ = EX. SIGN
 - ⊤ = EX. GAS MARKER
 - ⊥ = EX. LIGHT POLE
 - = EX. CATCH BASIN OR CLEANOUT

- ABBREVIATIONS**
- A ARC LENGTH
 - CH CHORD
 - CONC. CONCRETE
 - E EAST
 - FIP FOUND IRON PIPE
 - FIR FOUND IRON ROD
 - N NORTH
 - R RADIUS
 - R.O.W. RIGHT OF WAY
 - S SOUTH
 - W WEST
 - B.S.L. BUILDING SETBACK LINE
 - DOC. DOCUMENT
 - REC. RECORD INFORMATION
 - [XXX.X] DEED INFORMATION
 - XXX.XX MEASURED INFORMATION

REVISIONS:			
DATE	BY	DESCRIPTION	DATE

DRAWN BY: S.F.
 CHECKED BY: N.V.
 APPROVED BY: N.V.



35701 WEST AVENUE, SUITE 150
 WARRENVILLE, ILLINOIS 60555
 PHONE (630) 393-3060
 FAX (630) 393-2152

10 S. RIVERSIDE PLAZA, SUITE 875
 CHICAGO, ILLINOIS 60606
 PHONE (312) 474-7841
 FAX (312) 474-6099

2416 GALEN DRIVE
 CHAMPAIGN, ILLINOIS 61821
 PHONE (217) 351-6268
 FAX (217) 355-1902

PREPARED FOR:
TRINITAS DEVELOPMENT LLC

TITLE:
**UNION GARDENS
 EXISTING TOPOGRAPHICAL PLAN
 TRACT 2**

SCALE: 1"=50'
 DATE: 7-27-2018
 JOB NO: 180306
 SHEET 4 of 24

P.L.N.
 TRACT 1: 91-21-06-451-005
 TRACT 2: 30-21-06-326-015
 46-21-06-376-007
 TRACT 3: 46-21-06-376-008

PRELIMINARY/FINAL PLAT OF SUBDIVISION OF UNION GARDENS SUBDIVISION

PART OF THE SOUTH HALF OF SECTION 6, TOWNSHIP 19 NORTH, RANGE 9 EAST, OF THE THIRD PRINCIPAL MERIDIAN, CHAMPAIGN COUNTY, ILLINOIS

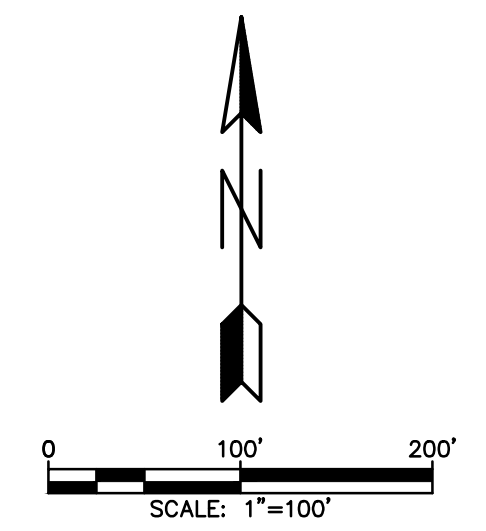

BASIS OF BEARING
 ILLINOIS STATE PLANE COORDINATE SYSTEM, EAST ZONE NAD 83 (2011).

- LEGEND**
- EX. PROPERTY LINE
 - - - EX. LOT LINE
 - - - EX. EASEMENT LINE
 - - - EX. CORPORATE LIMITS
 - - - CENTERLINE
 - - - EASEMENT LINE HEREBY GRANTED

- ABBREVIATIONS**
- | | |
|----------|-----------------------|
| A | ARC LENGTH |
| CH | CHORD |
| CONC. | CONCRETE |
| E | EAST |
| FIP | FOUND IRON PIPE |
| FIR | FOUND IRON ROD |
| N | NORTH |
| N.E.A. | NON-EASEMENT AREA |
| R | RADIUS |
| R.O.W. | RIGHT OF WAY |
| S | SOUTH |
| W | WEST |
| B.S.L. | BUILDING SETBACK LINE |
| DOC. | DOCUMENT |
| (xxx.xx) | RECORD INFORMATION |
| [xxx.xx] | DEED INFORMATION |
| xxx.xx | MEASURED INFORMATION |

- 1 CARVER PARK-HABITAT FOR HUMANITY REPLAT RECORDED OCTOBER 14, 2008 AS DOCUMENT NUMBER 2008R26341.
- 2 OAK TREE SUBDIVISION, OUTLOT 1 RECORDED NOVEMBER 7, 2017 AS DOCUMENT NUMBER 2017R21111.
- 3 OAK TREE SUBDIVISION, OUTLOT 2 RECORDED NOVEMBER 7, 2017 AS DOCUMENT NUMBER 2017R21111.
- 4 UNSUBDIVIDED 91-21-06-451-004

SURVEY AREA TABLE

LOT 1:	131,410 SQUARE FEET	(3.017 ACRES±)
LOT 2:	156,722 SQUARE FEET	(3.598 ACRES±)
LOT 3:	180,493 SQUARE FEET	(4.144 ACRES±)
LOT 4:	169,504 SQUARE FEET	(3.891 ACRES±)
LOT 5:	26,892 SQUARE FEET	(0.616 ACRES±)
LOT 6:	44,241 SQUARE FEET	(1.016 ACRES±)
LOT 7:	49,566 SQUARE FEET	(1.138 ACRES±)
LOT 8:	84,179 SQUARE FEET	(1.932 ACRES±)
LOT 9:	24,935 SQUARE FEET	(0.572 ACRES±)
LOT 10:	54,008 SQUARE FEET	(1.240 ACRES±)
LOT 11:	46,200 SQUARE FEET	(1.061 ACRES±)
LOT 12:	51,194 SQUARE FEET	(1.175 ACRES±)
LOT 13:	82,411 SQUARE FEET	(1.892 ACRES±)
OUTLOT A:	109,411 SQUARE FEET	(2.512 ACRES±)
OUTLOT B:	218,350 SQUARE FEET	(5.013 ACRES±)
OUTLOT C:	38,428 SQUARE FEET	(0.882 ACRES±)
OUTLOT D:	87,572 SQUARE FEET	(2.010 ACRES±)
R.O.W.:	189,174 SQUARE FEET	(4.343 ACRES±)
TOTAL:	1,744,691 SQUARE FEET	(40.053 ACRES±)

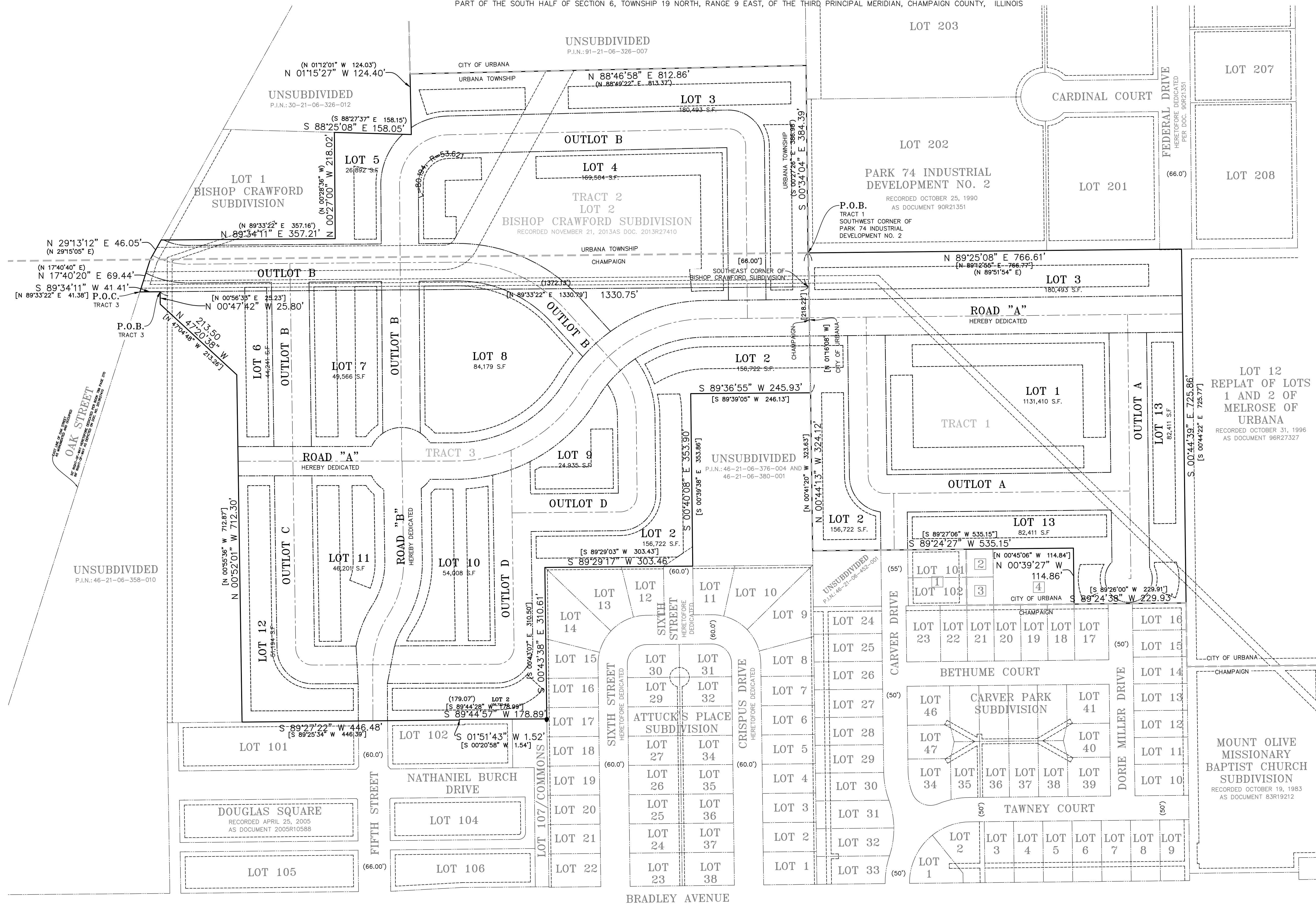

REVISIONS:

DATE	BY	DESCRIPTION	DATE	BY	DESCRIPTION

ENGINEERING RESOURCE ASSOCIATES
 35701 WEST AVENUE, SUITE 150
 WARRENVILLE, ILLINOIS 60055
 PHONE (630) 393-3060
 FAX (630) 393-2152

10 S. RIVERSIDE PLAZA, SUITE 875
 CHICAGO, ILLINOIS 60606
 PHONE (312) 474-7841
 FAX (312) 474-6099

2416 GALEN DRIVE
 CHAMPAIGN, ILLINOIS 61821
 PHONE (217) 351-6268
 FAX (217) 355-1902

PREPARED FOR:
TRINITAS DEVELOPMENT LLC

DRAWN BY: CNB
CHECKED BY: TBM
APPROVED BY: TBM

TITLE:
**UNION GARDENS
 PRELIMINARY/FINAL PLAT OF SUBDIVISION**

SCALE: 1"=100'
DATE: 7-27-2018
JOB NO.: 180306
SHEET 6 **OF** 24

PRELIMINARY/FINAL PLAT OF SUBDIVISION OF UNION GARDENS

Exhibit G - Preliminary Plat Sheets

P.I.N.
TRACT 1: 91-21-06-451-005
TRACT 2: 30-21-06-326-015
TRACT 3: 46-21-06-376-007
TRACT 3: 46-21-06-376-008

PART OF THE SOUTH HALF OF SECTION 6, TOWNSHIP 19 NORTH, RANGE 9 EAST, OF THE THIRD PRINCIPAL MERIDIAN, CHAMPAIGN COUNTY, ILLINOIS

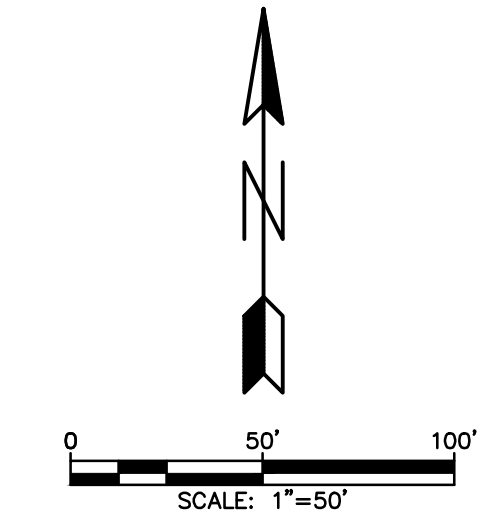
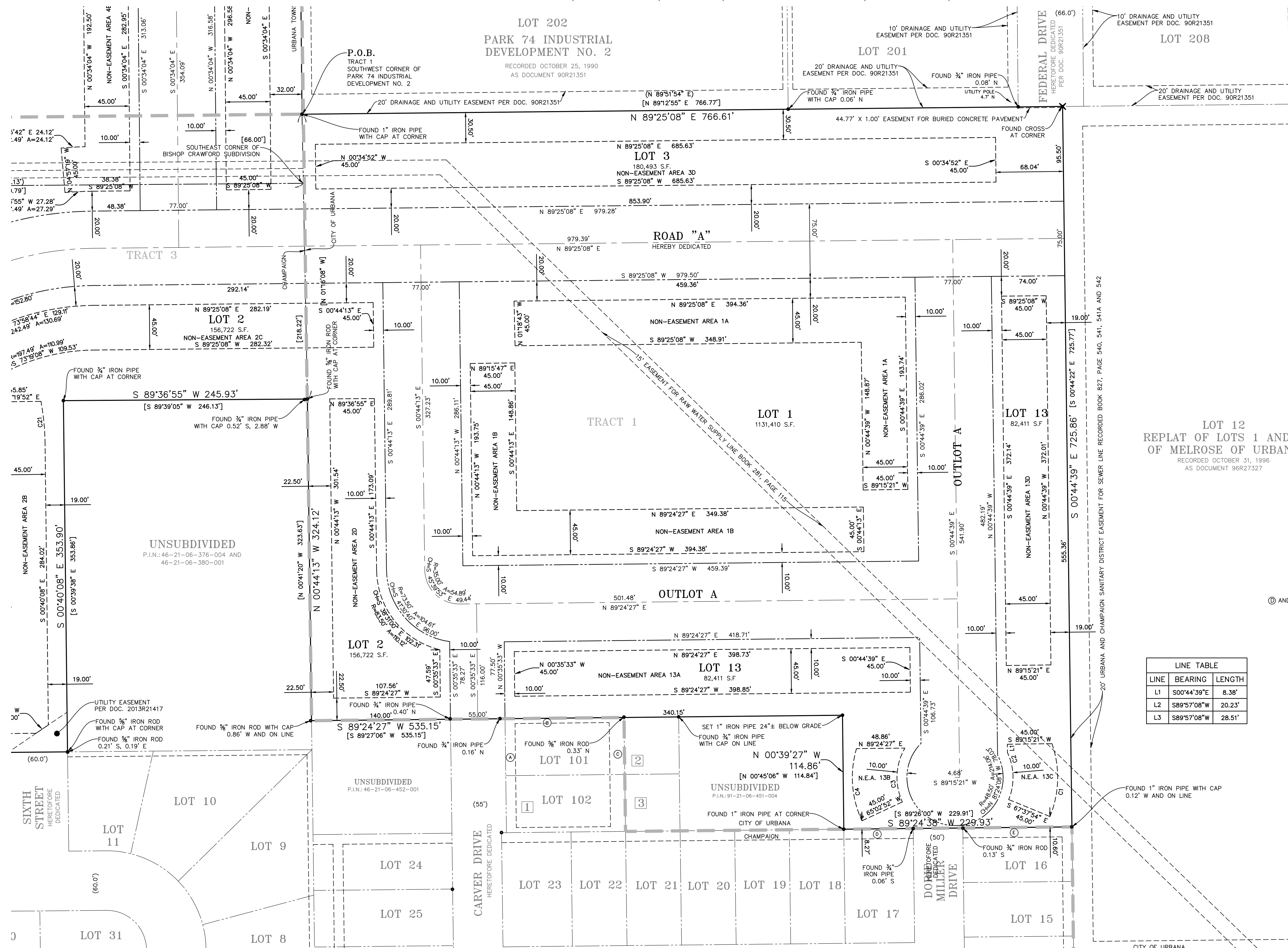

BASIS OF BEARING
ILLINOIS STATE PLANE COORDINATE
SYSTEM, EAST ZONE NAD 83 (2011).

LEGEND

---	EX. PROPERTY LINE
---	EX. LOT LINE
---	EX. EASEMENT LINE
---	EX. CORPORATE LIMITS
---	CENTERLINE
---	EASEMENT LINE HEREBY GRANTED

ABBREVIATIONS

A	ARC LENGTH
CH	CHORD
CONC.	CONCRETE
E	EAST
FIP	FOUND IRON PIPE
FIR	FOUND IRON ROD
N	NORTH
N.E.A.	NON-EASEMENT AREA
R	RADIUS
R.O.W.	RIGHT OF WAY
S	SOUTH
W	WEST
B.S.L.	BUILDING SETBACK LINE
DOC.	DOCUMENT
RECORD	RECORD INFORMATION
[XXX.XX]	DEED INFORMATION
XXX.XX	MEASURED INFORMATION

- 1 CARVER PARK-HABITAT FOR HUMANITY REPLAT RECORDED OCTOBER 14, 2008 AS DOCUMENT NUMBER 2008R26341.
- 2 OAK TREE SUBDIVISION, OUTLOT 1 RECORDED NOVEMBER 7, 2017 AS DOCUMENT NUMBER 2017R21111.
- 3 OAK TREE SUBDIVISION, OUTLOT 2 RECORDED NOVEMBER 7, 2017 AS DOCUMENT NUMBER 2017R21111.

Ⓐ AND Ⓑ : 15' PUBLIC UTILITY EASEMENT PER DOC. 2008R26341
 Ⓒ : 5' PUBLIC UTILITY EASEMENT PER DOC. 2008R26341
 Ⓓ AND Ⓔ : 10' EASEMENT FOR PUBLIC UTILITIES PER CARVER PARK SUBDIVISION

LINE TABLE

LINE	BEARING	LENGTH
L1	S00°44'39"E	8.38'
L2	S89°57'08"W	20.23'
L3	S89°57'08"W	28.51'

CURVE TABLE

CURVE	RADIUS	LENGTH	CHORD BEARING	CHORD
C1	103.50'	75.09'	N01°35'01"E	73.45'
C2	58.50'	48.75'	S01°30'16"E	47.35'
C3	58.50'	56.47'	S02°42'01"W	54.30'
C4	103.50'	74.53'	N04°19'28"W	72.93'
C5	83.50'	44.82'	N15°56'39"W	44.28'
C6	150.62'	26.18'	S05°56'53"W	26.14'
C7	89.00'	34.79'	S45°19'51"W	34.57'
C8	89.00'	26.62'	N48°51'41"W	26.52'
C9	69.00'	26.12'	S43°43'00"W	25.96'
C10	89.00'	11.31'	N43°50'15"E	11.30'
C11	69.00'	38.28'	N41°42'41"W	37.79'
C12	89.00'	25.01'	N42°16'43"W	24.93'
C13	100.32'	38.68'	S10°24'16"W	38.44'
C14	145.31'	56.04'	N10°24'11"E	55.69'
C15	141.69'	23.94'	N27°51'28"E	23.91'
C16	357.50'	45.29'	S82°56'41"W	45.26'
C17	83.50'	68.96'	N66°05'22"E	67.02'
C18	128.50'	106.13'	S66°05'22"W	103.14'
C19	198.50'	45.38'	N25°41'42"W	45.28'
C20	198.50'	42.36'	N06°46'55"W	42.28'
C21	243.50'	42.25'	S05°38'22"E	42.19'
C22	357.50'	12.61'	S61°54'04"W	12.61'

REVISIONS:

DATE	BY	DESCRIPTION	DATE	BY	DESCRIPTION

DRAWN BY: CNB
CHECKED BY: TBM
APPROVED BY: TBM



ENGINEERING RESOURCE ASSOCIATES
 35701 WEST AVENUE, SUITE 150
 WARRENVILLE, ILLINOIS 60555
 PHONE (630) 393-3060
 FAX (630) 393-2152

10 S. RIVERSIDE PLAZA, SUITE 875
 CHICAGO, ILLINOIS 60606
 PHONE (312) 474-7841
 FAX (312) 474-6099

2416 GALEN DRIVE
 CHAMPAIGN, ILLINOIS 61821
 PHONE (217) 351-6268
 FAX (217) 355-1902

PREPARED FOR:
TRINITAS DEVELOPMENT LLC

TITLE:
**UNION GARDENS
 PRELIMINARY/FINAL PLAT OF SUBDIVISION**

SCALE: 1"=50'
DATE: 7-27-2018
JOB NO: 180306
SHEET 7 **OF** 24

I:\PROJECTS\TRINITAS\180306-00 Champaign-Union Gardens\CAD Sheets\8056 TRINITAS SHEET PRELIMINARY PLAT OF SUBDIVISION.dwg 7/27/2018

PRELIMINARY/FINAL PLAT OF SUBDIVISION OF UNION GARDENS

PART OF THE SOUTH HALF OF SECTION 6, TOWNSHIP 19 NORTH, RANGE 9 EAST, OF THE THIRD PRINCIPAL MERIDIAN, CHAMPAIGN COUNTY, ILLINOIS

Exhibit G - Preliminary Plat Sheets

TRACT 1: 91-21-06-451-005
TRACT 2: 30-21-06-326-015
TRACT 3: 46-21-06-376-007
TRACT 3: 46-21-06-376-008

CURVE TABLE				
CURVE	RADIUS	LENGTH	CHORD BEARING	CHORD
C1	103.50'	75.09'	N01°35'01"E	73.45'
C2	58.50'	48.75'	S01°30'16"E	47.35'
C3	58.50'	56.47'	S02°42'01"W	54.30'
C4	103.50'	74.53'	N04°19'26"W	72.93'
C5	83.50'	44.82'	N15°56'39"W	44.28'
C6	150.62'	26.18'	S05°56'53"W	26.14'
C7	89.00'	34.79'	S45°19'51"W	34.57'
C8	89.00'	26.62'	N48°51'41"W	26.52'
C9	69.00'	26.12'	S43°43'00"W	25.96'
C10	89.00'	11.31'	N43°50'15"E	11.30'
C11	69.00'	38.28'	N41°42'41"W	37.79'
C12	89.00'	25.01'	N42°16'43"W	24.93'
C13	100.32'	38.68'	S10°24'16"W	38.44'
C14	145.31'	56.04'	N10°24'11"E	55.69'
C15	141.69'	23.94'	N27°51'28"E	23.91'
C16	357.50'	45.29'	S82°56'41"W	45.26'
C17	83.50'	68.96'	N66°05'22"E	67.02'
C18	128.50'	106.13'	S66°05'22"W	103.14'
C19	198.50'	45.38'	N25°41'42"W	45.28'
C20	198.50'	42.36'	N06°46'55"W	42.28'
C21	243.50'	42.25'	S05°38'22"E	42.19'
C22	357.50'	12.61'	S61°54'04"W	12.61'

LINE TABLE		
LINE	BEARING	LENGTH
L1	S00°44'39"E	8.38'
L2	S89°57'08"W	20.23'
L3	S89°57'08"W	28.51'

LEGEND	
---	EX. PROPERTY LINE
---	EX. LOT LINE
---	EX. EASEMENT LINE
---	EX. CORPORATE LIMITS
---	CENTERLINE
---	EASEMENT LINE HEREBY GRANTED

ABBREVIATIONS	
A	ARC LENGTH
CH	CHORD
CONC.	CONCRETE
E	EAST
FIP	FOUND IRON PIPE
FIR	FOUND IRON ROD
N	NORTH
R	RADIUS
R.O.W.	RIGHT OF WAY
S	SOUTH
W	WEST
B.S.L.	BUILDING SETBACK LINE
DOC.	DOCUMENT
(XXX.XX)	RECORD INFORMATION
[XXX.XX]	DEED INFORMATION
XXX.XX	MEASURED INFORMATION

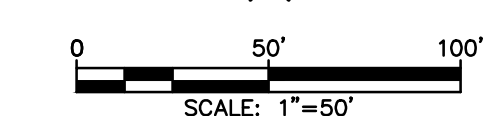

BASIS OF BEARING
ILLINOIS STATE PLANE COORDINATE
SYSTEM, EAST ZONE NAD 83 (2011).

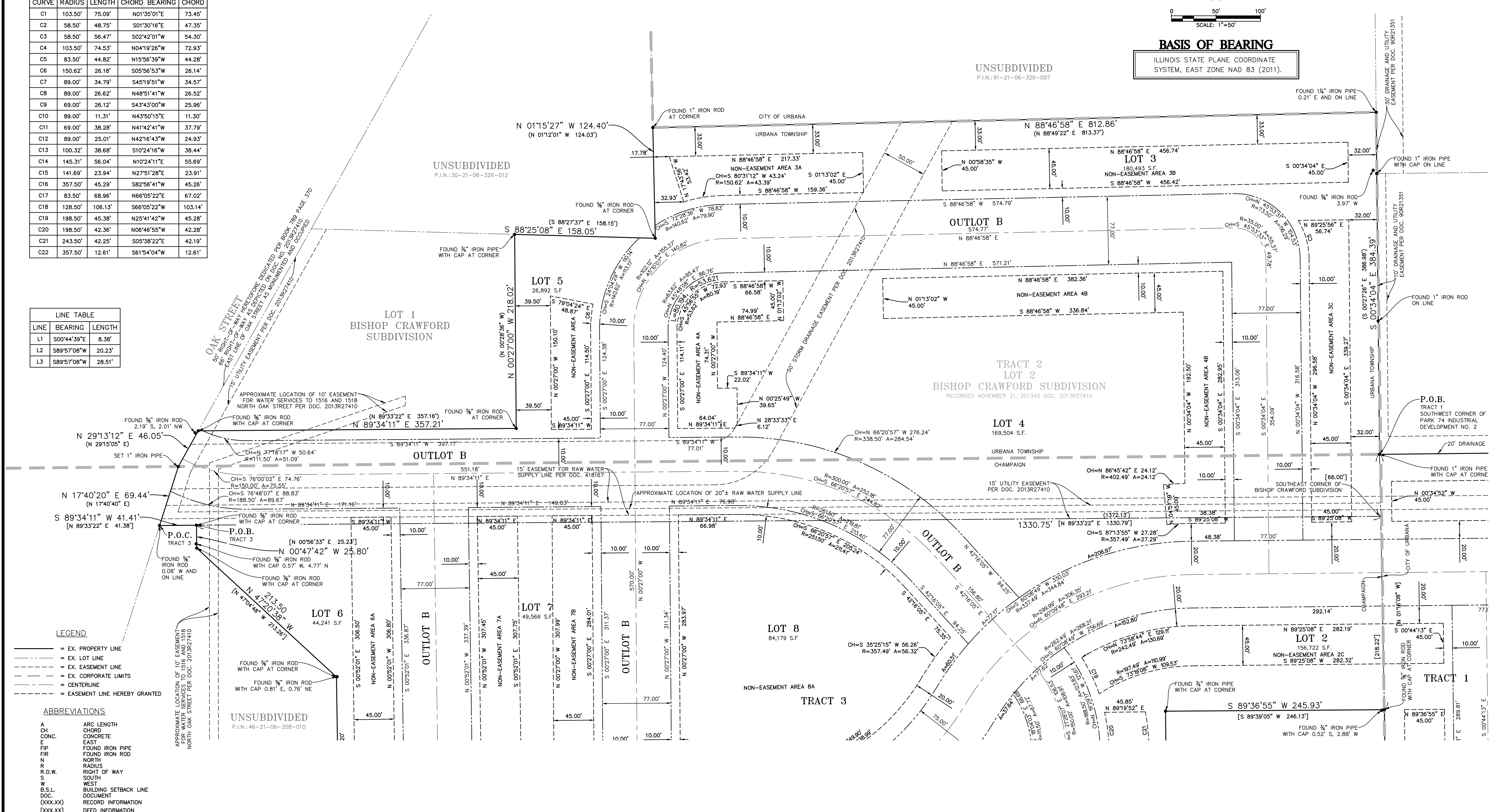

REVISIONS:				
DATE	BY	DESCRIPTION	DATE	BY

DRAWN BY: CNB
CHECKED BY: TBM
APPROVED BY: TBM

ENGINEERING RESOURCE ASSOCIATES

35701 WEST AVENUE, SUITE 150
WARRENVILLE, ILLINOIS 60555
PHONE (630) 393-3060
FAX (630) 393-2152

10 S. RIVERSIDE PLAZA, SUITE 875
CHICAGO, ILLINOIS 60606
PHONE (312) 474-7841
FAX (312) 474-6099

2416 GALEN DRIVE
CHAMPAIGN, ILLINOIS 61821
PHONE (217) 351-6268
FAX (217) 355-1902

PREPARED FOR:
TRINITAS DEVELOPMENT LLC

TITLE:
**UNION GARDENS
PRELIMINARY/FINAL PLAT OF SUBDIVISION**

SCALE: 1"=50'
DATE: 7-27-2018
JOB NO: 180306
SHEET 8 **OF** 24

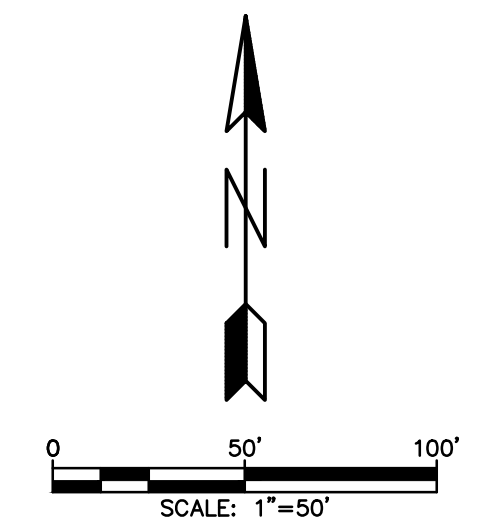

BASIS OF BEARING

ILLINOIS STATE PLANE COORDINATE SYSTEM, EAST ZONE NAD 83 (2011).

LEGEND

- EX. PROPERTY LINE
- - - EX. LOT LINE
- · - · EX. EASEMENT LINE
- - - EX. CORPORATE LIMITS
- - - CENTERLINE
- - - EASEMENT LINE HEREBY GRANTED

ABBREVIATIONS

- A ARC LENGTH
- CH CHORD
- CONC. CONCRETE
- E EAST
- FIP FOUND IRON PIPE
- FIR FOUND IRON ROD
- N NORTH
- N.E.A. NON-EASEMENT AREA
- R RADIUS
- R.O.W. RIGHT OF WAY
- S SOUTH
- S.W. WEST
- B.S.L. BUILDING SETBACK LINE
- DOC. DOCUMENT
- (XXX.XX) RECORD INFORMATION
- [XXX.XX] DEED INFORMATION
- XXX.XX MEASURED INFORMATION

DETAIL

SCALE: 1"=4'

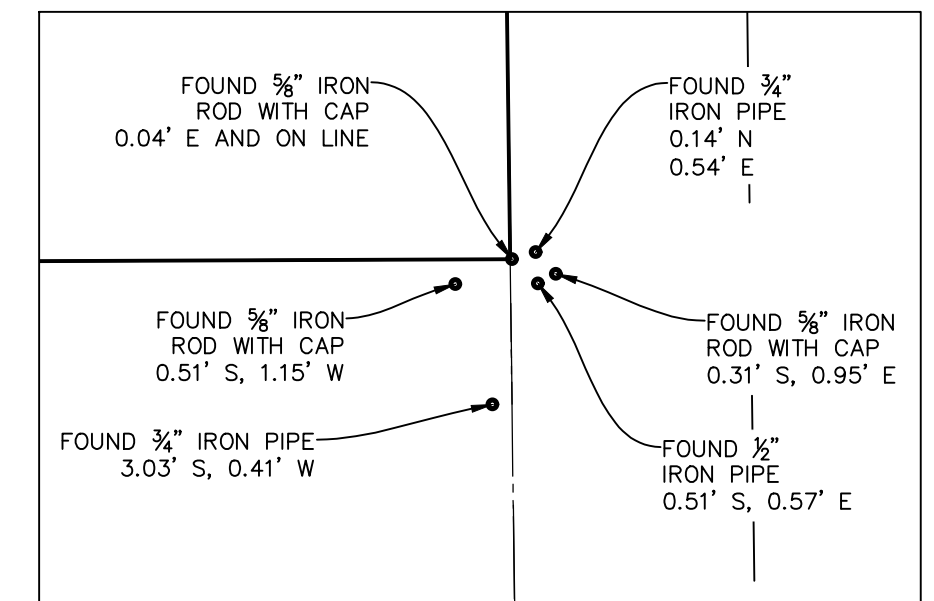

CURVE TABLE				
CURVE	RADIUS	LENGTH	CHORD BEARING	CHORD
C1	103.50'	75.09'	N01°35'01"E	73.45'
C2	58.50'	48.75'	S01°30'16"W	47.35'
C3	58.50'	56.47'	S02°42'01"W	54.30'
C4	103.50'	74.53'	N04°19'28"W	72.93'
C5	83.50'	44.82'	N15°56'39"W	44.28'
C6	150.62'	26.18'	S05°56'53"W	26.14'
C7	89.00'	34.79'	S45°19'51"W	34.57'
C8	89.00'	26.62'	N48°51'41"W	26.52'
C9	69.00'	26.12'	S43°43'00"W	25.96'
C10	89.00'	11.31'	N43°50'15"E	11.30'
C11	69.00'	38.28'	N41°42'41"W	37.79'
C12	89.00'	25.01'	N42°16'43"W	24.93'
C13	100.32'	38.68'	S10°24'16"W	38.44'
C14	145.31'	56.04'	N10°24'11"E	55.69'
C15	141.69'	23.94'	N27°51'28"E	23.91'
C16	357.50'	45.29'	S82°56'41"W	45.26'
C17	83.50'	68.96'	N66°05'22"E	67.02'
C18	128.50'	106.13'	S66°05'22"W	103.14'
C19	198.50'	45.38'	N25°41'42"W	45.28'
C20	198.50'	42.36'	N06°46'55"W	42.28'
C21	243.50'	42.25'	S05°38'22"E	42.19'
C22	357.50'	12.61'	S61°54'04"W	12.61'

LINE TABLE		
LINE	BEARING	LENGTH
L1	S00°44'39"E	8.38'
L2	S89°57'08"W	20.23'
L3	S89°57'08"W	28.51'

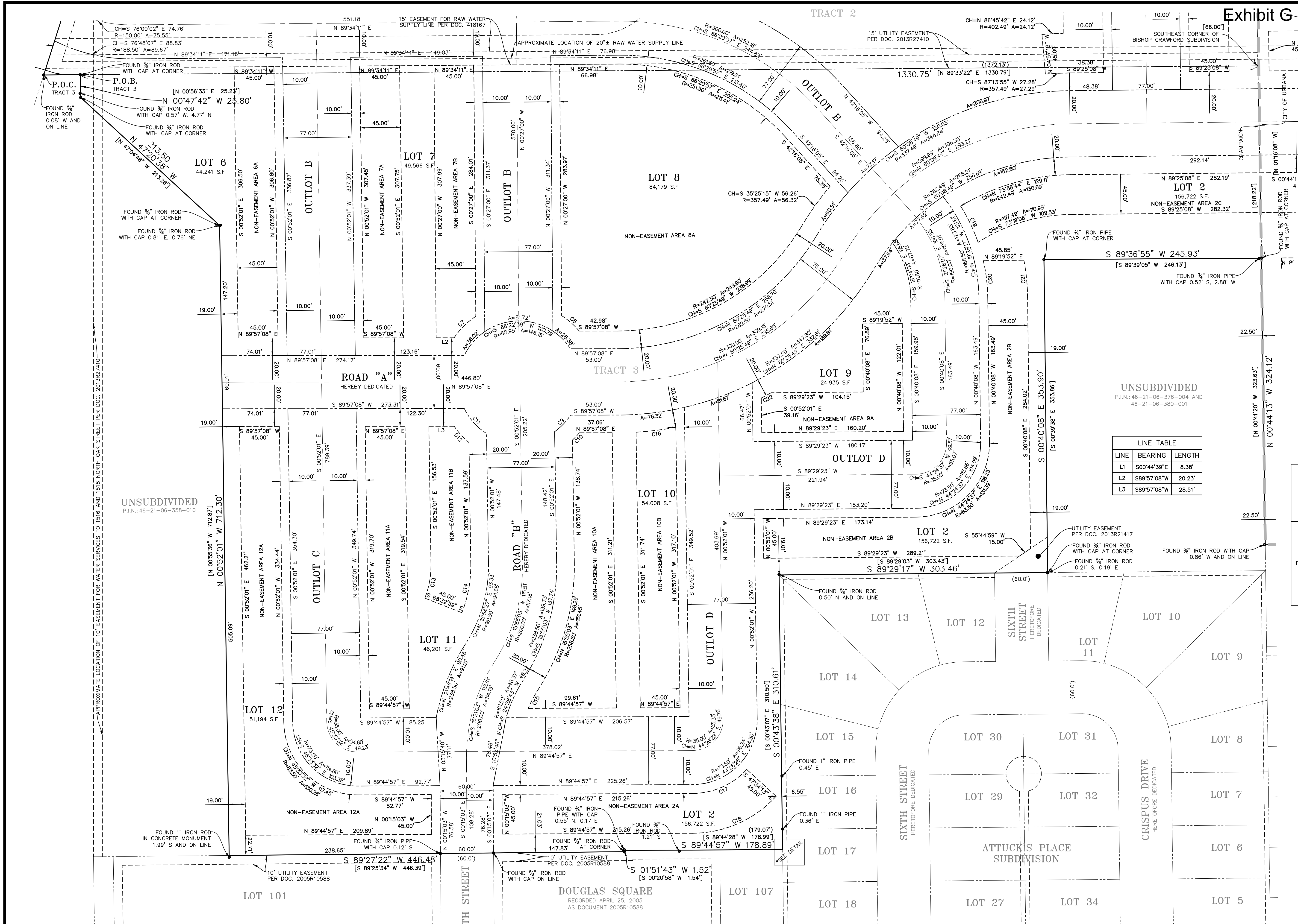

REVISIONS:					
DATE	BY	DESCRIPTION	DATE	BY	DESCRIPTION

ENGINEERING RESOURCE ASSOCIATES
 35701 WEST AVENUE, SUITE 150
 WARRENVILLE, ILLINOIS 60555
 PHONE (630) 393-3060
 FAX (630) 393-2152

10 S. RIVERSIDE PLAZA, SUITE 875
 CHICAGO, ILLINOIS 60606
 PHONE (312) 474-7841
 FAX (312) 474-6099

2416 GALEN DRIVE
 CHAMPAIGN, ILLINOIS 61821
 PHONE (217) 351-6268
 FAX (217) 355-1902

PREPARED FOR:
TRINITAS DEVELOPMENT LLC

TITLE:
**UNION GARDENS
 PRELIMINARY/FINAL PLAT OF SUBDIVISION**

SCALE: 1"=50'
 DATE: 7-27-2018
 JOB NO: 180306
 SHEET 9 OF 24

PRELIMINARY/FINAL PLAT OF SUBDIVISION OF UNION GARDENS

PART OF THE SOUTH HALF OF SECTION 6, TOWNSHIP 19 NORTH, RANGE 9 EAST, OF THE THIRD PRINCIPAL MERIDIAN, CHAMPAIGN COUNTY, ILLINOIS

Exhibit G - Preliminary Plat Sheets

THIS PLAT HAS BEEN SUBMITTED FOR
RECORDING BY AND RETURN TO:

NAME: CITY OF URBANA
ADDRESS: 400 SOUTH VINE STREET
URBANA, ILLINOIS 61801

AND/OR

NAME: CITY OF CHAMPAIGN
ADDRESS: 102 NORTH NEIL STREET
CHAMPAIGN, ILLINOIS 61820

OWNER'S CERTIFICATE

STATE OF ILLINOIS }
COUNTY OF _____ } SS

THIS IS TO CERTIFY THAT THE UNDERSIGNED IS THE OWNER OF THE LAND DESCRIBED ABOVE AND THAT NO OTHER PERSON HAS ANY RIGHT, TITLE, OR INTEREST IN SAID LAND, AND THAT SAID OWNERS HAS CAUSED THE SAME TO BE SURVEYED AND SUBDIVIDED AS INDICATED THEREON, FOR THE USES AND PURPOSES THEREIN SET FORTH, AND TO HEREBY ACKNOWLEDGE AND ADOPT THE SAME UNDER THE STYLE AND TITLE THEREON INDICATED.

DATED THIS _____ DAY OF _____, A.D. 20 _____

(NAME)

(ADDRESS)

NOTARY CERTIFICATE

STATE OF ILLINOIS }
COUNTY OF _____ } SS

I, _____, A NOTARY PUBLIC IN AND FOR THE RESIDING IN THE COUNTY AND STATE AFORESAID, DO HEREBY CERTIFY THAT _____ PERSONALLY KNOWN TO ME TO BE AS SUCH OWNER(S) APPEARED BEFORE ME THIS DAY IN PERSON AND ACKNOWLEDGED THAT HE/THEY SIGNED AND DELIVERED THE PLAT AS HIS/THEIR FREE AND VOLUNTARY ACT FOR THE USES AND PURPOSES THEREIN SET FORTH.

GIVEN UNDER MY HAND AND NOTARIAL SEAL THIS _____ DAY OF _____, A.D. 20 _____

NOTARY PUBLIC

MY COMMISSION EXPIRES: _____

SCHOOL DISTRICT BOUNDARY STATEMENT

STATE OF ILLINOIS }
COUNTY OF _____ } SS

THE UNDERSIGNED, BEING DULY SWORN, UPON HIS OATH DEPOSES AND STATES THE FOLLOWING:

THAT HE/SHE IS THE OWNER OF THE PROPERTY LEGALLY DESCRIBED ON A PROPOSED PLAT OF SUBDIVISION SUBMITTED TO THE CITY FOR APPROVAL, WHICH LEGAL DESCRIPTION IS ATTACHED HERETO AND INCORPORATED BY REFERENCE HEREIN; AND TO THE BEST OF THE OWNERS KNOWLEDGE THE SCHOOL DISTRICT(S) IN WHICH EACH TRACT, PARCEL, LOT OR BLOCK OF THE PROPOSED SUBDIVISION LIES ARE

(SCHOOL DISTRICT NAME)

(ADDRESS)

DATED THIS _____ DAY OF _____, A.D. 20 _____

OWNER(S)

ENGINEER'S SURFACE WATER DRAINAGE CERTIFICATE

STATE OF ILLINOIS }
COUNTY OF _____ } SS

THIS IS TO CERTIFY THAT I, A REGISTERED PROFESSIONAL ENGINEER, CERTIFY THAT TO THE BEST OF MY KNOWLEDGE AND BELIEF THE DRAINAGE OF SURFACE WATERS WILL NOT BE CHANGED BY THE CONSTRUCTION OF SUCH SUBDIVISION OR ANY PART THEREOF, OR THAT, IF SUCH SURFACE WATER DRAINAGE WILL BE CHANGED, ADEQUATE PROVISION HAVE BEEN MADE FOR COLLECTION AND DIVERSION OF SUCH SURFACE WATERS INTO PUBLIC AREAS, OR DRAINS WHICH THE SUBDIVIDER HAS A RIGHT TO USE, AND THAT SUCH SURFACE WATERS WILL NOT BE DEPOSITED ON THE PROPERTY OF ADJOINING LAND OWNERS IN SUCH CONCENTRATIONS AS MAY CAUSE DAMAGE TO THE ADJOINING PROPERTY BECAUSE OF THE CONSTRUCTION OF SAID SUBDIVISION.

DATED THIS _____ DAY OF _____, A.D. 20 _____

(NAME)

(ADDRESS)

STATE REGISTRATION NUMBER _____

CITY OF URBANA PLAN COMMISSION CERTIFICATE

STATE OF ILLINOIS }
COUNTY OF CHAMPAIGN } SS

THIS IS TO CERTIFY THAT THE MEMBERS OF THE PLAN COMMISSION OF THE CITY OF URBANA, ILLINOIS HAVE REVIEWED AND APPROVED THIS PLAT.

DATED AT URBANA, CHAMPAIGN COUNTY, ILLINOIS

THIS _____ DAY OF _____, A.D., 20 _____

CHAIRMAN

SECRETARY

URBANA CITY ENGINEER CERTIFICATE

STATE OF ILLINOIS }
COUNTY OF CHAMPAIGN } SS

I, _____, CITY ENGINEER OF THE CITY OF URBANA, ILLINOIS, HEREBY CERTIFY THAT THE LAND IMPROVEMENTS DESCRIBED IN THIS PLAT AND THE PLANS AND SPECIFICATIONS THEREOF MEET THE MINIMUM REQUIREMENTS OF THE CITY AND HAVE BEEN APPROVED BY ALL PUBLIC AUTHORITIES HAVING JURISDICTION THEREOF.

DATED AT URBANA, CHAMPAIGN COUNTY, ILLINOIS,

THIS _____ DAY OF _____, 20 _____

CITY ENGINEER

REGISTRATION NUMBER _____

CITY OF CHAMPAIGN PLAN COMMISSION CERTIFICATE

STATE OF ILLINOIS }
COUNTY OF CHAMPAIGN } SS

THIS IS TO CERTIFY THAT THE MEMBERS OF THE PLAN COMMISSION OF THE CITY OF CHAMPAIGN, ILLINOIS HAVE REVIEWED AND APPROVED THIS PLAT.

DATED AT CHAMPAIGN, CHAMPAIGN COUNTY, ILLINOIS

THIS _____ DAY OF _____, A.D., 20 _____

CHAIRMAN

SECRETARY

CHAMPAIGN CITY ENGINEER CERTIFICATE

STATE OF ILLINOIS }
COUNTY OF CHAMPAIGN } SS

I, _____, CITY ENGINEER OF THE CITY OF CHAMPAIGN, ILLINOIS, HEREBY CERTIFY THAT THE LAND IMPROVEMENTS DESCRIBED IN THIS PLAT AND THE PLANS AND SPECIFICATIONS THEREOF MEET THE MINIMUM REQUIREMENTS OF THE CITY AND HAVE BEEN APPROVED BY ALL PUBLIC AUTHORITIES HAVING JURISDICTION THEREOF.

DATED AT CHAMPAIGN, CHAMPAIGN COUNTY, ILLINOIS,

THIS _____ DAY OF _____, 20 _____

CITY ENGINEER

REGISTRATION NUMBER _____

URBANA CITY COLLECTOR CERTIFICATE

STATE OF ILLINOIS }
COUNTY OF CHAMPAIGN } SS

I, _____, COLLECTOR FOR THE CITY OF URBANA, ILLINOIS, DO HEREBY CERTIFY THAT THERE ARE NO DELINQUENT OR UNPAID OR FORFEITED SPECIAL ASSESSMENTS OR ANY DEFERRED INSTALLMENTS THEREOF THAT HAVE BEEN APPORTIONED AGAINST THE TRACT OF LAND INCLUDED IN THIS PLAT.

DATED AT URBANA, CHAMPAIGN COUNTY, ILLINOIS,

THIS _____ DAY OF _____, A.D., 20 _____

CITY COLLECTOR

CHAMPAIGN CITY COLLECTOR CERTIFICATE

STATE OF ILLINOIS }
COUNTY OF CHAMPAIGN } SS

I, _____, COLLECTOR FOR THE CITY OF CHAMPAIGN, ILLINOIS, DO HEREBY CERTIFY THAT THERE ARE NO DELINQUENT OR UNPAID OR FORFEITED SPECIAL ASSESSMENTS OR ANY DEFERRED INSTALLMENTS THEREOF THAT HAVE BEEN APPORTIONED AGAINST THE TRACT OF LAND INCLUDED IN THIS PLAT.

DATED AT CHAMPAIGN, CHAMPAIGN COUNTY, ILLINOIS,

THIS _____ DAY OF _____, A.D., 20 _____

CITY COLLECTOR

PRIVATE ACCESS EASEMENT PROVISIONS

AN EASEMENT IS HEREBY GRANTED ACROSS OUTLOTS A, B, C AND D TO THE OWNERS OF ALL LOTS WITHIN TRINITAS SUBDIVISION AS SHOWN HEREON, THEIR SUCCESSORS AND ASSIGNS, VISITORS AND THEIR DESIGNEES FOR PERPETUAL PEDESTRIAN USE, ENJOYMENT, PEDESTRIAN INGRESS AND EGRESS, AND ALSO FOR THE PERPETUAL VEHICULAR ACCESS AND VEHICULAR INGRESS AND EGRESS OVER THE PAVED ROADWAY WITHIN SAID LOTS. OUTLOTS A, B, C AND D SHALL NOT BE USED BY SAID OWNERS, SUCCESSORS AND ASSIGNS, VISITORS AND DESIGNEES IN A MANNER THAT WOULD BLOCK OR RESTRICT THE ACCESS AND FREE FLOW OF TRAFFIC TO ANY INDIVIDUAL LOT PLATTED HEREON.

URBANA CITY COUNCIL CERTIFICATE

STATE OF ILLINOIS }
COUNTY OF CHAMPAIGN } SS

THIS IS TO CERTIFY THAT THE CITY COUNCIL OF THE CITY OF URBANA, CHAMPAIGN COUNTY, ILLINOIS, HAS REVIEWED AND APPROVED THIS PLAT.

DATED AT URBANA, CHAMPAIGN COUNTY, ILLINOIS

THIS _____ DAY OF _____, A.D., 20 _____

MAYOR

ATTTEST:
CITY CLERK

CHAMPAIGN CITY COUNCIL CERTIFICATE

STATE OF ILLINOIS }
COUNTY OF CHAMPAIGN } SS

THIS IS TO CERTIFY THAT THE CITY COUNCIL OF THE CITY OF CHAMPAIGN, CHAMPAIGN COUNTY, ILLINOIS, HAS REVIEWED AND APPROVED THIS PLAT.

DATED AT CHAMPAIGN, CHAMPAIGN COUNTY, ILLINOIS

THIS _____ DAY OF _____, A.D., 20 _____

MAYOR

ATTTEST:
CITY CLERK

CITY OF URBANA CLERK CERTIFICATE

STATE OF ILLINOIS }
COUNTY OF CHAMPAIGN } SS

I, _____, CITY CLERK OF THE CITY OF URBANA, ILLINOIS HEREBY CERTIFY THAT THE PLAT WAS PRESENTED TO AND BY RESOLUTION DULY APPROVED BY THE CITY COUNCIL OF SAID CITY AT ITS MEETING HELD ON _____, 20 _____, AND THAT THE REQUIRED BOND OR OTHER GUARANTEE HAS BEEN POSTED FOR THE COMPLETION OF THE IMPROVEMENTS BY THE REGULATIONS OF SAID CITY.

IN WITNESS WHEREOF, I HAVE HERETO SET MY HAND AND SEAL OF THE CITY OF URBANA, ILLINOIS,

THIS _____ DAY OF _____, A.D., 20 _____

CITY CLERK

CITY OF CHAMPAIGN CLERK CERTIFICATE

STATE OF ILLINOIS }
COUNTY OF CHAMPAIGN } SS

I, _____, CITY CLERK OF THE CITY OF CHAMPAIGN, ILLINOIS HEREBY CERTIFY THAT THE PLAT WAS PRESENTED TO AND BY RESOLUTION DULY APPROVED BY THE CITY COUNCIL OF SAID CITY AT ITS MEETING HELD ON _____, 20 _____, AND THAT THE REQUIRED BOND OR OTHER GUARANTEE HAS BEEN POSTED FOR THE COMPLETION OF THE IMPROVEMENTS BY THE REGULATIONS OF SAID CITY.

IN WITNESS WHEREOF, I HAVE HERETO SET MY HAND AND SEAL OF THE CITY OF CHAMPAIGN, ILLINOIS,

THIS _____ DAY OF _____, A.D., 20 _____

CITY CLERK

BLANKET EASEMENT PROVISIONS

A PERPETUAL EASEMENT, DESIGNATED FOR OVERHEAD, UNDERGROUND, AND SURFACE PUBLIC UTILITIES AND DRAINAGE, ARE HEREBY RESERVED FOR, AND GRANTED TO, COUNTY OF CHAMPAIGN, AMEREN ILLINOIS, COMCAST CABLE COMMUNICATIONS, INC. (CABLE TV), AND AT&T ILLINOIS (TELEPHONE), THEIR SUCCESSORS AND ASSIGNEES, IN ALL OF LOTS 1-12 EXCEPT WHERE BUILDING STRUCTURES WILL LIE IN NON-EASEMENT AREAS, INCLUDING ALL PLATTED EASEMENT AREAS, STREETS, AND OTHER PUBLIC WAYS AND PLACES SHOWN ON THIS PLAT, SAID EASEMENT SHALL BE FOR THE INSTALLATION, MAINTENANCE, RELOCATION, RENEWAL AND REMOVAL OF ANY AND ALL PUBLIC UTILITIES, DRAINAGE LOCALITIES, AND RELATED APPURTENANCES IN, OVER, ACROSS, ALONG, AND UPON THE SO DESIGNATED PROPERTY.

SAID EASEMENT SHALL INCLUDE THE RIGHT TO ENTER THE SUBDIVIDED PROPERTY FOR ALL SUCH PURPOSES, AND THE RIGHT WITHOUT LIABILITY TO CUT, TRIM, ALTER, OR REMOVE ANY VEGETATION, ROOTS, STRUCTURES, OR DEVICES WITHIN THE DESIGNATED EASEMENT PROPERTY AS MAY BE REASONABLY REQUIRED INCIDENT TO THE RIGHTS HEREIN GIVEN WITHOUT CONSENT OF GRANTEEES. NO BUILDINGS, STRUCTURES, OR OTHER OBSTRUCTION SHALL BE CONSTRUCTED, PLANTED, OR PLACED IN ANY SUCH EASEMENT AREA, STREETS, OR OTHER PUBLIC WAYS OR PLACES, NOR SHALL ANY OTHER USES BE MADE THERE OF WHICH WILL INTERFERE WITH THE EASEMENTS RESERVED AND GRANTED HEREBY.

SUCH EASEMENT SHALL FURTHER BE FOR THE PURPOSES OF SERVING ALL AREAS SHOWN ON THIS PLAT AS WELL AS OTHER PROPERTY, WHETHER OR NOT CONTIGUOUS THERETO, WITH GAS, ELECTRIC, TELEPHONE, CABLE T.V., WATER MAINS, SANITARY AND STORM SEWERS, AND SHALL INCLUDE THE RIGHT TO OVERHANG ALL LOTS WITH AERIAL SERVICE WIRES TO SERVE ADJACENT LOTS WHERE NECESSARY AND APPROVED BY THE CITY OF URBANA AND THE CITY OF CHAMPAIGN. BUT SUCH AERIAL SERVICE WIRES SHALL NOT PASS THROUGH PERMANENT IMPROVEMENTS ON SUCH LOTS. SUCH EASEMENT SHALL SURVIVE THE VACATION BY THE PROPER AUTHORITY OF ANY STREETS AND OTHER PUBLIC WAY AND PLACE SHOWN ON THIS PLAT UNLESS OTHERWISE EXPRESSLY MENTIONED IN THE ORDINANCE OF VACATION.

COUNTY CLERK'S CERTIFICATE

STATE OF ILLINOIS }
COUNTY OF CHAMPAIGN } SS

I, _____, COUNTY CLERK OF CHAMPAIGN COUNTY, ILLINOIS DO HEREBY CERTIFY THAT THERE ARE NO DELINQUENT GENERAL TAXES, NO UNPAID CURRENT GENERAL TAXES, NO FORFEITED TAXES, AND NO REDEEMABLE TAX SALES AGAINST ANY OF THE LAND INCLUDED IN THE PLAT.

I FURTHER CERTIFY THAT I HAVE RECEIVED ALL STATUTORY FEES IN CONNECTION WITH THE PLAT.

GIVEN UNDER MY HAND AND SEAL OF THE COUNTY CLERK OF CHAMPAIGN COUNTY, ILLINOIS, THIS

_____ DAY OF _____, A.D., 20 _____

COUNTY CLERK

COUNTY RECORDER'S CERTIFICATE

STATE OF ILLINOIS }
COUNTY OF CHAMPAIGN } SS

THIS PLAT WAS FILED FOR RECORD IN THE RECORDER'S OFFICE OF CHAMPAIGN COUNTY, ILLINOIS, ON THE

_____ DAY OF _____, A.D., 20 _____, AT _____ O'CLOCK _____ M. AS DOCUMENT NUMBER _____

COUNTY RECORDER

SURVEYOR'S CERTIFICATE

STATE OF ILLINOIS }
COUNTY OF DUPAGE } SS

THIS IS TO CERTIFY THAT I, TIMOTHY B. MARTINEK, AN ILLINOIS PROFESSIONAL LAND SURVEYOR NO. 035-003782, HAVE SURVEYED AND SUBDIVIDED THE FOLLOWING DESCRIBED PROPERTY:

TRACT 1: BEGINNING AT AN IRON ROD SITUATED IN THE SOUTH ONE-HALF OF SECTION 6, TOWNSHIP 19 NORTH, RANGE 9 EAST, OF THE THIRD PRINCIPAL MERIDIAN, CITY OF URBANA, CHAMPAIGN COUNTY, ILLINOIS, SAID IRON PIPE ALSO BEING A PART OF THE BOUNDARY MONUMENTS OF THE CHURCH OF THE LIVING GOD PLAT OF SURVEY, RECORDED AS DOCUMENT NO. 2011R22983, IN THE OFFICE OF THE CHAMPAIGN COUNTY RECORDER, SAID PIPE ALSO BEING SITUATED AT THE SOUTHWEST CORNER OF PARK 74 INDUSTRIAL DEVELOPMENT NO.2; THENCE NORTH 89 DEGREES 12 MINUTES 45 SECONDS EAST, ALONG THE SOUTH LINE OF SAID SUBDIVISION, A DISTANCE OF 766.77 FEET TO A CHISELED CROSS SITUATED AT THE NORTHWEST CORNER OF THE REPLATS OF LOTS 1 AND 2 OF MELROSE OF URBANA; THENCE SOUTH 00 DEGREES 44 MINUTES 22 SECONDS EAST, ALONG THE WEST LINE OF SAID REPLATS OF LOTS 1 AND 2, A DISTANCE OF 725.77 FEET TO AN IRON ROD BEARING A DAMAGED CAP SITUATED AT THE NORTHEAST CORNER OF CARVER PARK SUBDIVISION TO URBANA; THENCE SOUTH 89 DEGREES 26 MINUTES 00 SECONDS WEST, ALONG THE NORTH LINE OF SAID SUBDIVISION, A DISTANCE OF 229.51 FEET TO AN IRON PIPE FOUND SITUATED AT THE NORTHEAST CORNER OF LOT 18 OF SAID SUBDIVISION; THENCE NORTH 00 DEGREES 45 MINUTES 06 SECONDS WEST, A DISTANCE OF 114.84 FEET TO AN IRON ROD BEARING A CAP STAMPED 2537 SAID ROD ALSO BEING SITUATED ON THE EASTERLY EXTENSION OF THE NORTH LINE OF LOT 48 OF SAID CARVER PARK SUBDIVISION; THENCE SOUTH 89 DEGREES 27 MINUTES 06 SECONDS WEST, ALONG SAID EXTENSION, A DISTANCE OF 535.15 FEET TO A ROD BEARING A CAP STAMPED 2537 SITUATED ON THE EAST LINE OF THE BAPTIST MISSIONARY CHURCH PROPERTY; THENCE NORTH 00 DEGREES 41 MINUTES 20 SECONDS WEST, ALONG SAID EAST LINE OF THE CHURCH PROPERTY, A DISTANCE OF 323.63 FEET TO AN IRON ROD BEARING A CAP STAMPED 1462; THENCE NORTH 01 DEGREES 16 MINUTES 08 SECONDS WEST, A DISTANCE OF 218.22 FEET TO AN IRON ROD SITUATED AT THE SOUTHEAST CORNER OF THE BISHOP CRAWFORD SUBDIVISION, AS SAID SUBDIVISION IS RECORDED AS DOCUMENT NO. 2013R27410, DATED NOVEMBER 21, 2013, IN THE OFFICE OF THE AFORESAID CHAMPAIGN COUNTY RECORDER, THENCE CONTINUING NORTH 01 DEGREES 16 MINUTES 08 SECONDS WEST, A DISTANCE OF 66.00 FEET TO THE POINT OF BEGINNING, BEING SITUATED WITHIN THE LIMITS OF THE CITY OF URBANA, IN CHAMPAIGN COUNTY, ILLINOIS.

TRACT 2: LOT 2 OF BISHOP CRAWFORD SUBDIVISION, AS PER PLAT RECORDED NOVEMBER 21, 2013 AS DOCUMENT NUMBER 2013R27410, SITUATED IN CHAMPAIGN COUNTY, ILLINOIS.

TRACT 3: COMMENCING AT AN IRON ROD BEARING A CAP STAMPED REX 2537 SITUATED ON THE EAST RIGHT OF WAY LINE OF OAK STREET, ALSO BEING SITUATED AT THE SOUTHWEST CORNER OF THE BISHOP CRAWFORD SUBDIVISION SITUATED IN THE SOUTH ONE-HALF OF SECTION 6, TOWNSHIP 19 NORTH, RANGE 9 EAST, OF THE THIRD PRINCIPAL MERIDIAN, CITY OF CHAMPAIGN AND THE CITY OF URBANA, CHAMPAIGN COUNTY, ILLINOIS, AS SAID SUBDIVISION IS RECORDED ON DOCUMENT NO. 2013R27410, DATED NOVEMBER 21, 2013, IN THE OFFICE OF THE CHAMPAIGN COUNTY RECORDER; THENCE EASTERLY ALONG THE SOUTH LINE OF SAID SUBDIVISION ON A BEARING OF NORTH 89 DEGREES 33 MINUTES 22 SECONDS EAST, A DISTANCE OF 41.36 FEET, TO AN IRON ROD BEARING A CAP STAMPED REX 2537 SITUATED AT THE TRUE POINT OF BEGINNING; THENCE CONTINUING NORTH 89 DEGREES 33 MINUTES 22 SECONDS EAST, ALONG SAID SOUTH LINE, A DISTANCE OF 1330.79 FEET TO AN IRON ROD BEARING A CAP STAMPED REX 2537 SITUATED AT THE SOUTHWEST CORNER OF SAID BISHOP CRAWFORD SUBDIVISION; THENCE SOUTH 01 DEGREES 01 MINUTES 16 SECONDS EAST, A DISTANCE OF 218.21 FEET TO AN IRON ROD BEARING A CAP STAMPED 1462; SAID IRON ROD ALSO BEING SITUATED AT THE NORTHEAST CORNER OF THE BAPTIST MISSIONARY CHURCH PROPERTY; THENCE SOUTH 89 DEGREES 39 MINUTES 05 SECONDS WEST, ALONG THE NORTH LINE OF SAID CHURCH PROPERTY A DISTANCE OF 246.13 FEET; THENCE SOUTH 00 DEGREES 39 MINUTES 38 SECONDS EAST, ALONG THE WEST LINE OF SAID CHURCH PROPERTY, A DISTANCE OF 353.86 FEET TO AN IRON ROD BEARING A CAP STAMPED 1462, SITUATED AT THE NORTHEAST CORNER OF LOT 11 OF ATTUCK'S PLACE SUBDIVISION; THENCE SOUTH 89 DEGREES 29 MINUTES 03 SECONDS WEST, ALONG THE NORTH LINE OF SAID ATTUCK'S SUBDIVISION, A DISTANCE OF 303.43 FEET TO A POINT SITUATED 0.50 FEET SOUTH OF AN IRON PIPE BEARING A CAP STAMPED 1462; SAID PIPE ALSO SITUATED IN THE NORTH ROOT OF A LARGE LOCUST TREE, AFORESAID POINT ALSO BEING THE NORTHWEST CORNER OF SAID ATTUCK'S PLACE SUBDIVISION; THENCE SOUTH 00 DEGREES 43 MINUTES 07 SECONDS EAST, ALONG THE WEST LINE OF SAID ATTUCK'S SUBDIVISION, A DISTANCE OF 310.50 FEET TO AN IRON ROD BEARING A CAP STAMPED 1462, SITUATED AT THE NORTHEAST CORNER OF DOUGLAS SQUARE SUBDIVISION; THENCE SOUTH 89 DEGREES 58 MINUTES 44 SECONDS WEST, ALONG THE NORTH LINE OF SAID DOUGLAS SQUARE SUBDIVISION, A DISTANCE OF 178.99 FEET TO AN IRON ROD BEARING A CAP STAMPED HEC; THENCE SOUTH 00 DEGREES 20 MINUTES 58 SECONDS WEST, ALONG SAID NORTH LINE, A DISTANCE OF 1.54 FEET TO AN IRON ROD STAMPED HEC; THENCE SOUTH 89 DEGREES 25 MINUTES 34 SECONDS WEST, ALONG SAID NORTH LINE, A DISTANCE OF 446.39 FEET TO A POINT SITUATED 2.13 FEET NORTH OF A CONCRETE MONUMENT, THENCE NORTH 00 DEGREES 55 MINUTES 49 SECONDS WEST, A DISTANCE OF 712.87 FEET; THENCE NORTH 47 DEGREES 04 MINUTES 48 SECONDS WEST, A DISTANCE OF 213.26 FEET; THENCE NORTH 00 DEGREES 56 MINUTES 33 SECONDS EAST, A DISTANCE OF 25.23 FEET TO THE POINT OF BEGINNING, BEING SITUATED WITHIN THE LIMITS OF THE CITY OF CHAMPAIGN, IN CHAMPAIGN COUNTY, ILLINOIS.

AS SHOWN BY THE ANNEXED PLAT WHICH IS A CORRECT REPRESENTATION OF SAID SURVEY AND SUBDIVISION, ALL DISTANCES ARE SHOWN IN FEET AND DECIMALS THEREOF. I FURTHER CERTIFY THAT ALL REGULATIONS ENACTED BY THE CITY OF URBANA AND THE CITY OF CHAMPAIGN RELATIVE TO PLATS AND SUBDIVISIONS HAVE BEEN COMPLIED WITH IN THE PREPARATION OF THIS PLAT.

I DO HEREBY CERTIFY THAT THE PROPERTY DESCRIBED HEREON FALLS IN ZONE X, ZONE X IS DEFINED AS AREAS DETERMINED TO BE OUTSIDE THE 0.2% CHANCE FLOODPLAIN, ACCORDING TO THE FEDERAL EMERGENCY MANAGEMENT AGENCY FLOOD INSURANCE RATE MAP NUMBER 17019C0313D WITH AN EFFECTIVE DATE OF OCTOBER 2, 2013.

I FURTHER CERTIFY THAT, PORTIONS OF THIS SUBDIVISION LIE WITHIN THE CORPORATE LIMITS OF THE CITY OF URBANA AND THE CITY OF CHAMPAIGN, WHICH HAS ADOPTED AN OFFICIAL COMPREHENSIVE PLAN AND IS EXERCISING THE SPECIAL POWERS AUTHORIZED BY DIVISION 12 OF ARTICLE 11 OF THE ILLINOIS MUNICIPAL CODE, AS HERETOFORE AND HEREAFTER AMENDED.

I HEREBY GRANT PERMISSION TO THE THE CITY OF URBANA CLERK AND THE CITY OF CHAMPAIGN CLERK OR AN EMPLOYEE OF THE CITY OF URBANA AND THE CITY OF CHAMPAIGN CLERK'S OFFICES TO RECORD THIS PLAT. THE REPRESENTATIVES SHALL PROVIDE THE SURVEYOR WITH A RECORDED COPY OF THIS PLAT.

GIVEN UNDER MY HAND AND SEAL THIS _____ DAY OF _____, 20 _____

FOR REVIEW ONLY

ILLINOIS PROFESSIONAL LAND SURVEYOR NO. 035-003782
LICENSE EXPIRES NOVEMBER 30, 2018

DESIGN FIRM PROFESSIONAL LICENSE NO. 184.001186
LICENSE EXPIRES APRIL 30, 2019

DATE OF FIELD SURVEY: MAY 7, 2018

THIS PROFESSIONAL SERVICE CONFORMS TO THE CURRENT ILLINOIS
MINIMUM STANDARDS FOR A BOUNDARY SURVEY.



REVISIONS:					
DATE	BY	DESCRIPTION	DATE	BY	DESCRIPTION

DRAWN BY: CNB
CHECKED BY: TBM
APPROVED BY: TBM



35701 WEST AVENUE, SUITE 150
WARRENVILLE, ILLINOIS 60555
PHONE (630) 393-3066
FAX (630) 393-2152

10 S. RIVERSIDE PLAZA , SUITE 875
CHICAGO, ILLINOIS 60606
PHONE (312) 474-7841
FAX (312) 474-6099

2416 GALEN DRIVE
CHAMPAIGN, ILLINOIS 61821
PHONE (217) 351-6268
FAX (217) 355-1902

PREPARED FOR:

TRINITAS DEVELOPMENT LLC

TITLE:

UNION GARDENS
PRELIMINARY/FINAL PLAT OF SUBDIVISION

SCALE: N/A
DATE: 7-27-2018
JOB NO: 161210
SHEET 10 OF 24